

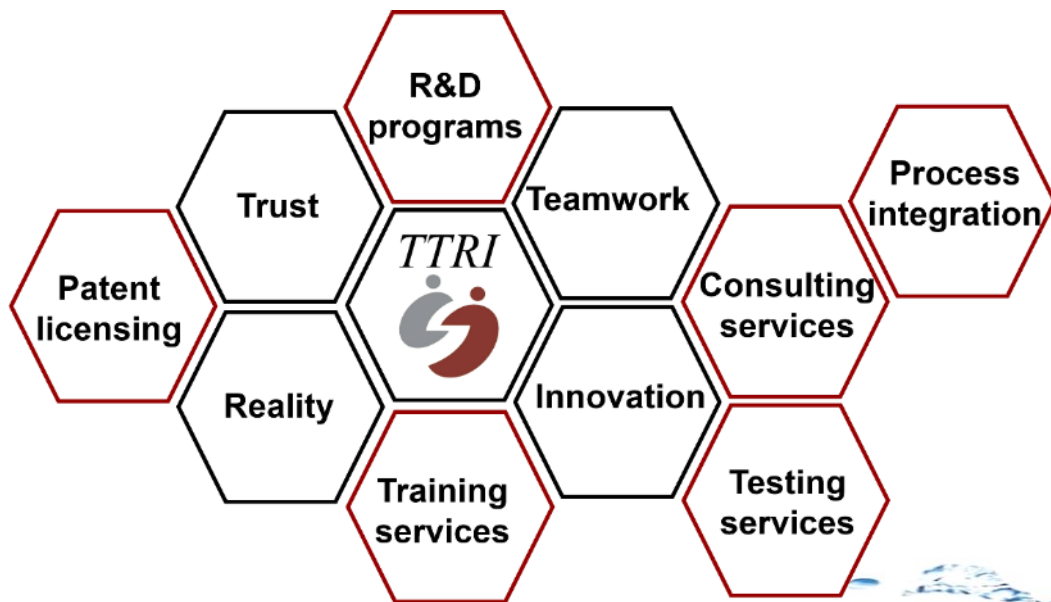

Filtration Testing



About TTRI

The Taiwan Textile Research Institute (TTRI), established in 1959 as the Taiwan Textile Testing Center, is about to reach its 60th anniversary and has been involved in various phases of the development of the Taiwanese textile industry. TTRI has made a remarkable and revolutionary structure reform, and transformed into a more visionary and innovative R&D teamwork framework as well as a more supportive administrative system. TTRI has extended its service capability from fiber spinning, fabric formation, dyeing and finishing, apparel manufacturing, as well as textile testing. Undoubtedly, TTRI has integrated inside itself to consolidate its service strength and competitiveness in the domestic and international community.

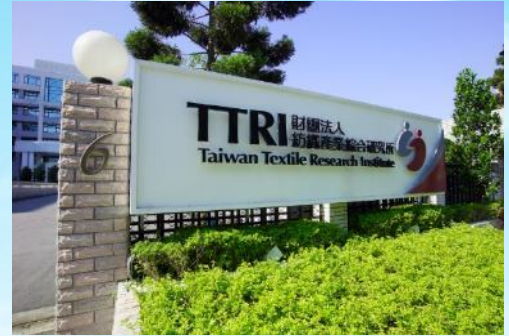

Laboratory Accreditation (ISO 17025)

TTRI has been serving textile industries for 60 years. Apart from the same services given by ITS, SGS commercial testing laboratories, TTRI is also capable of providing new textiles testing methods and apparatus. In particular, Filtration Testing has been very popular in recent years and several testing apparatus have been developed by TTRI to assist industry to quantify their product performance to assure the quality of the products. The laboratory has been accredited by CNLA, TAF (Taiwan Accreditation Foundation) since 1998 and many test items have been accredited, including several filtration testing items.

ISO 9001



ISO 17025



Air filtration testing

- **Ventilation filter** (ASHRAE 52.2; EN 779; **ISO 16890**)
- **HEPA/ULPA filter** (EN 1822-4; EN 1822-5)
- **Cabin air filter** (ISO 11155-1; ISO 11155-2)
- **Engine intake filter** (SAE J726 ; ISO 5011)
- **Flat sheet filter media** (EN 1822-3; TSI 8130)
- **Compressed air filter** (ISO 12500-1; ISO 12500-2; ISO 12500-4)
- **Cleanable filter media** (ISO 11057; VDI 3926)
- **Breach test, up to 6000 Pa**



Breach test

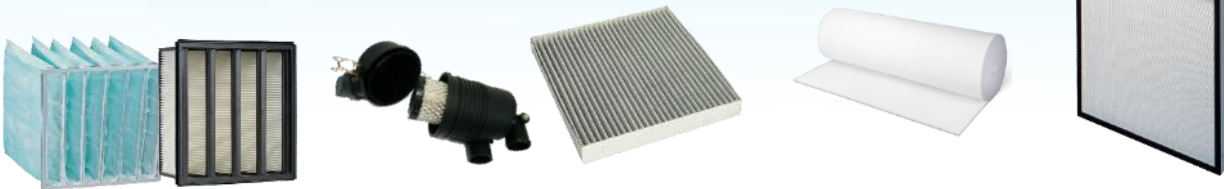

Testing items of the major performances:

- Pressure drop versus air flow rate for clean filter
- Initial pressure drop and initial efficiency
- Dust loading capacity
- Efficiency after different dust loading phases and average efficiency
- Efficiency and filter scanning for HEPA/ULPA filter
- Most penetrating particle size (MPPS) for filtration media



ASHRAE Dust

ISO A2 Fine Dust

KCl (Salt aerosol)



PSL

DEHS(Oil aerosol)

KCl aqueous solution(30%)
NaCl aqueous solution (2%)

Ventilation filter testing

Testing standard:

ISO 16890 Air filters for general ventilation:

Part 1: Technical specifications, requirements and classification system based upon particulate matter efficiency (ePM)

Part 2: Measurement of fractional efficiency and air flow resistance

Part 3: Determination of the gravimetric efficiency and the air flow resistance versus the mass of test dust captured

Part 4: Conditioning method to determine the minimum fractional test efficiency

EN 779:2012 Particulate air filters for general ventilation. Determination of the filtration performance

ASHRAE 52.2-2017 Method of Testing General Ventilation Air-Cleaning Devices For Removal Efficiency By Particle Size

ASHRAE 52.2:2017 Classification of air filter

	E1 0.3~1.0 μ m	E2 1.0~3.0 μ m	E3 3.0~10.0 μ m	Average Arrestance
MERV 1	—	—	<20%	<65%
MERV 2	—	—	<20%	$\geq 65\%$
MERV 3	—	—	<20%	$\geq 70\%$
MERV 4	—	—	<20%	$\geq 75\%$
MERV 5	—	—	$\geq 20\%$	—
MERV 6	—	—	$\geq 35\%$	—
MERV 7	—	—	$\geq 50\%$	—
MERV 8	—	$\geq 20\%$	$\geq 70\%$	—
MERV 9	—	$\geq 35\%$	$\geq 75\%$	—
MERV 10	—	$\geq 50\%$	$\geq 80\%$	—
MERV 11	$\geq 20\%$	$\geq 65\%$	$\geq 85\%$	—
MERV 12	$\geq 35\%$	$\geq 80\%$	$\geq 90\%$	—
MERV 13	$\geq 50\%$	$\geq 85\%$	$\geq 90\%$	—
MERV 14	$\geq 75\%$	$\geq 90\%$	$\geq 95\%$	—
MERV 15	$\geq 85\%$	$\geq 90\%$	$\geq 95\%$	—
MERV 16	$\geq 95\%$	$\geq 95\%$	$\geq 95\%$	—

MERV : Minimum Efficiency Reporting Value

EN 779:2012 Classification of air filter

Group	Class	Final pressure drop (Pa)	Average Arrestance (A_m)	Average Efficiency (E_m) of $0.4 \mu m$	Minimum Efficiency of $0.4 \mu m$
Coarse	G1	250	$50\% \leq A_m < 65\%$		
	G2	250	$65\% \leq A_m < 80\%$		
	G3	250	$80\% \leq A_m < 90\%$		
	G4	250	$90\% \leq A_m$		
Medium	M5	450		$40\% \leq E_m < 60\%$	
	M6	450		$60\% \leq E_m < 80\%$	
Fine	F7	450		$80\% \leq E_m < 90\%$	MTE $\geq 35\%$
	F8	450		$90\% \leq E_m < 95\%$	MTE $\geq 55\%$
	F9	450		$95\% \leq E_m$	MTE $\geq 70\%$

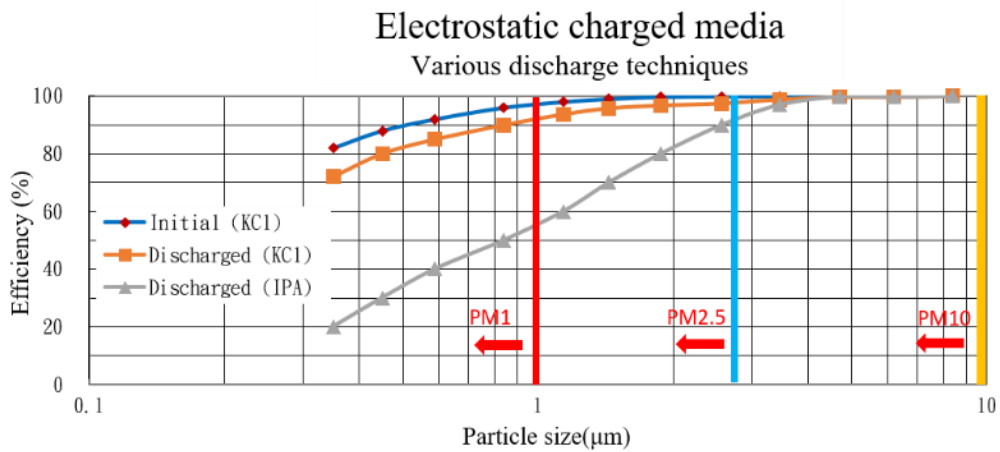

ISO 16890 Classification of air filter

	Group designation	Requirement			Class reporting value
		ePM _{1,min}	ePM _{2.5,min}	ePM ₁₀	
Coarse Filter	ISO Coarse	-	-	<50%	Initial arrestance
Fine Filter	ISO ePM10	-	-	≥ 50%	ISO ePM10
	ISO ePM2.5	-	≥ 50%	-	ISO ePM2.5
	ISO ePM1	≥ 50%	-	-	ISO ePM1

	ASHRAE 52.2	EN 779	ISO 16890
Aerosol	KCl (Salt aerosol)	DEHS (Liquid aerosol)	KCl/DEHS
Particle range	0.3~10 μm	0.2~3 μm	0.3~1.0μm (DEHS) 1.0~10μm (KCl)
Test dust	ASHRAE	ASHRAE	ISO 15957 L2 (ISO Fine A2)
Dust concentration	70 mg/m ³	70 mg/m ³	140 mg/m ³
Conditioning method	KCl aerosol for filter	IPA soaking for media	IPA soaking for filter
Final resistance	350 Pa (undischarged filter)	250/450 Pa (undischarged filter)	200/300 Pa (undischarged filter)
Classification method	MERV (MERV-A)	Average efficiency @0.4μm	ISO ePM _x (x= Coarse, 10,2.5, 1)
Group/Grade	16 grades	3 groups (G, M, F)/ 9 grades	4 groups (ISO Coarse, ISO ePM10, ISO ePM2.5, ISO ePM1) / 49 grades

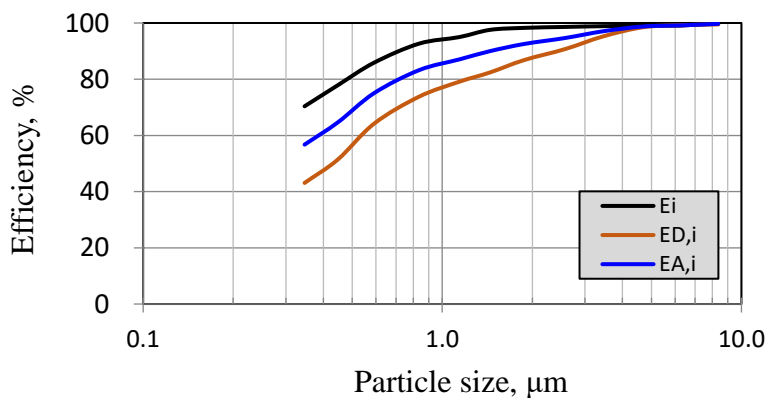

Fig. ISO 16890 Fractional efficiency by particle size

High efficiency air filters

Testing standards

EN 1822 (ISO 29463) High efficiency air filters (EPA, HEPA and ULPA).

- Part 1 Classification, performance testing, marking
- Part 2 Aerosol production, measuring equipment, particle counting statistics
- Part 3 Testing flat sheet filter media
- Part 4 Determining leakage of filter element (scan method)
- Part 5 Determining the efficiency of filter elements

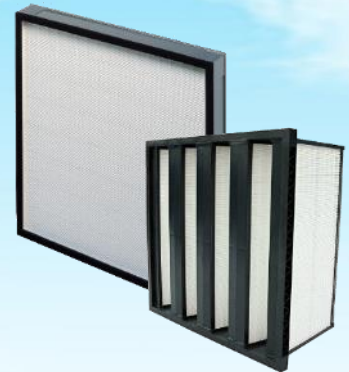

IEST-RP-CC001 HEPA and ULPA Filters

IEST-RP-CC007 Testing ULPA Filters

IEST-RP-CC021 Testing HEPA and ULPA Filter Media

IEST-RP-CC034 HEPA and ULPA Filter Leak Tests

Filter Class	Overall value		Filter Class
	Efficiency (%)	Penetration (%)	
ISO 29463			EN 1822
	≥ 85	≤ 15	E10
ISO 15 E	≥ 95	≤ 5	E11
ISO 20 E	≥ 99.0	≤ 1	
ISO 25 E	≥ 99.5	≤ 0.5	E12
ISO 30 E	≥ 99.90	≤ 0.1	
ISO 35 H	≥ 99.95	≤ 0.05	H13
ISO 40 H	≥ 99.990	≤ 0.01	
ISO 45 H	≥ 99.995	≤ 0.005	H14
ISO 50 U	≥ 99.9990	≤ 0.001	
ISO 55 U	≥ 99.9995	≤ 0.0005	U15

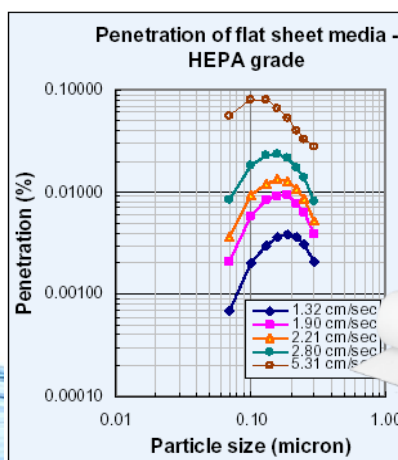

Capillary Flow Porometer

The Capillary Flow Porometer provides fully automated through-pore analysis.

Testing items :

- bubble point,
- pore size distribution,
- mean pore size.

Testing sample: filter media, membranes, paper and battery separators.

Pore Size Range: 0.013 - 500 microns

Sample Size: 0.5" - 2.5" diameter

Pressure Range: 0 - 150 PSI

Mass Flow :10 cc/minute - 500 L/minute

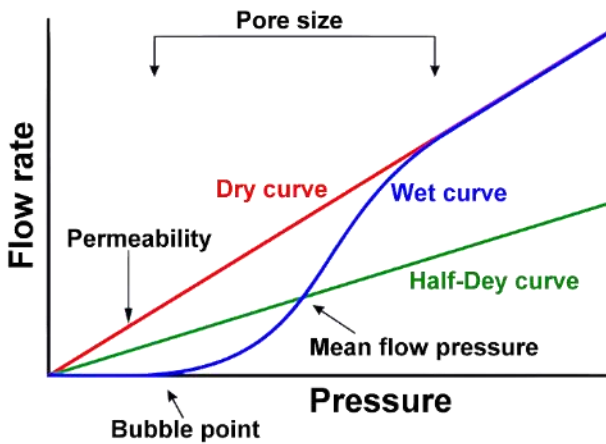
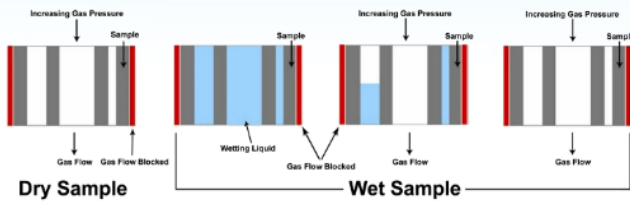
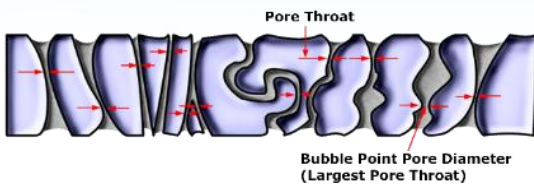
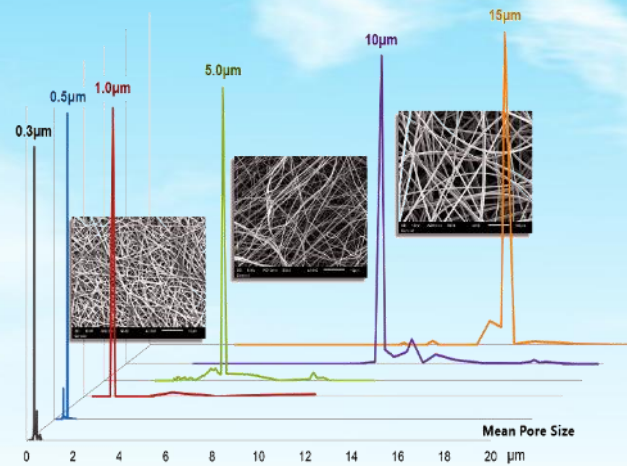

Integrity and first bubble point testing



Oil filtration efficiency

Applicable Standards:

ISO 16889: Hydraulic fluid power filters

ISO 19438: Diesel fuel and petrol filter

ISO 4548-12: Lubricating oil filter

Flow range: 1~7 l/min, 7~40 l/min and 40~200 l/min

Particle size: 4 to 70 μm(c), 64 channels

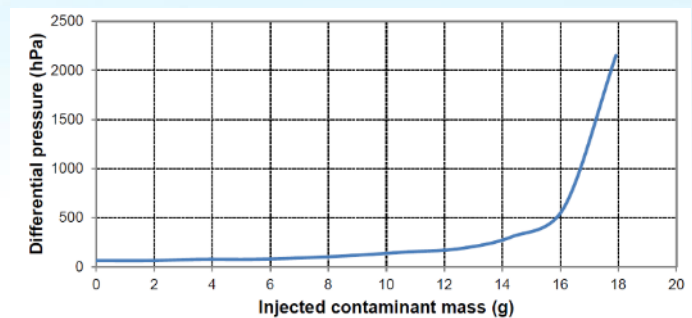
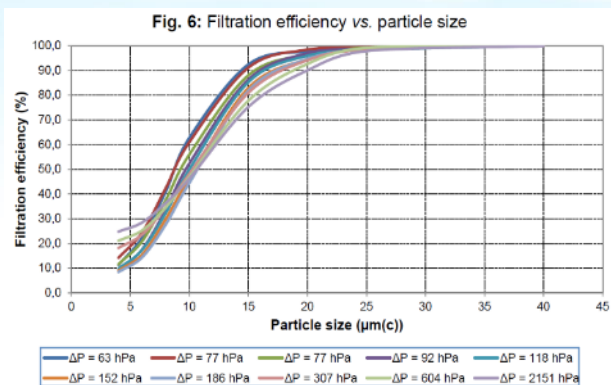

Water filtration

Applicable Standards:

EN 13443-2 Water conditioning equipment inside buildings. Mechanical filters. Particle rating 1 μm to less than 80 μm. Requirements for performance, safety and testing.

Max flow rate: 40 l/min

Max pressure drop: 10 bar

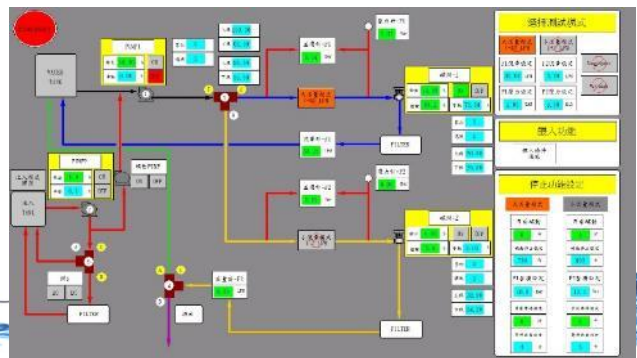

Medical Textile

Medical Face Mask (ASTM F2100; EN 14683)

- Resistance to penetration by synthetic blood (ASTM F1862)
- Bacterial (Virus) filtration efficiency (ASTM F2101)
- Particulate filtration efficiency (ASTM F2299)
- Differential pressure (MIL-M-36954C)
- Flammability (EN 13274-4; 16 CFR 1610)



This test method of BFE uses *Staphylococcus aureus* as the challenge organism. The use of *S. aureus* is based on its clinical relevance as a leading cause of nosocomial infections.

BFE test



S. aureus

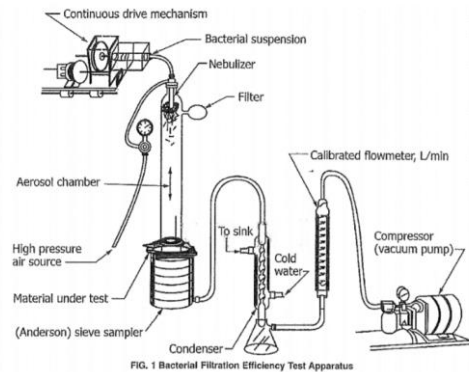
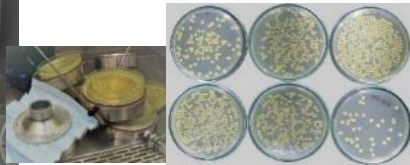

Against house dust mite (ISO 21326, JIS L1920)

The efficacy of products against house dust mite in textiles.

1. Repelling method by using Petri dish
2. Repelling method by using glass tube
3. Proliferation method by using Petri dish and using vial
4. Penetration method



glass tube

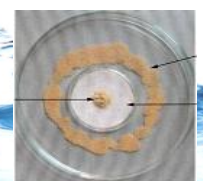

Petri dish

ASTM F2100:2019 Material requirements by performance level

Characteristic	Level 1 Barrier	Level 2 Barrier	Level 3 Barrier
Bacterial filtration efficiency, %	≥95	≥98	≥98
Differential pressure, mmH ₂ O/cm ²	<5.0	<6.0	<6.0
Sub-micron particulate filtration efficiency at 0.1 micron, %	≥95	≥98	≥98
Resistance to penetration by synthetic blood, minimum pressure in mm Hg for pass result	80	120	160
Flame spread	Class 1	Class 1	Class 1

EN 14683:2019 Performance requirements for medical face masks

Characteristic	Type I ^a	Type II	Type IIR
Bacterial filtration efficiency, %	≥95	≥98	≥98
Differential pressure, Pa/cm ²	<40	<40	<60
Splash resistance pressure, kPa	Not required	Not required	≥16
Microbial cleanliness, cfu/g	≤30	≤30	≤30

a Type I medical face masks should only be used for patients and other persons to reduce the risk of spread of infections particularly in epidemic or pandemic situations. Type I masks are not intended for use by healthcare professionals in an operating room or in other medical settings with similar requirements.

Disposable Dust Respirators (NIOSH 42 CFR 84)

PM2.5 Mask (CNS 15980)

Breathing System Filters

- **Virus filtration efficiency**
- Bacterial filtration efficiency
- Particulate efficiency (ISO 23328-1)

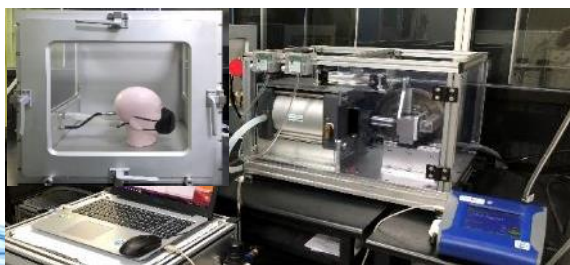

Protection efficiency of PM2.5 mask



Surgical Gowns and Drapes

Surgical gowns are used to minimize the transmission of infective agents between patients and clinical staff during surgical and other invasive procedures.

Applicable Standards:

BS EN 13795:2019 Surgical clothing and drapes. Requirements and test methods. Part 1: Surgical drapes and gowns.

BS EN 13795-2:2019 Surgical clothing and drapes. Requirements and test methods. Part 2: Clean air suits

ANSI/AAMI PB70:2012: Liquid barrier performance and classification of protective apparel and drapes intended for use in health care facilities



BS EN 13795:2019 Performance requirements for surgical clothing and drapes

Characteristic	Test method	Unit	Type	Requirement			
				Standard performance		High performance	
				Critical product area	Less critical product area	Critical product area	Less critical product area
Microbial penetration -Dry	EN ISO 22612	CFU	Gowns /Drpaes	Not required	≤ 300	Not required	≤ 300
			Air suits	≤ 100		≤ 50	
Microbial penetration -Wet	EN ISO 22612	I _B	Gowns /Drpaes	≥ 2.8	Not required	6.0	Not required
Cleanliness microbial/ Bioburden	EN ISO 11737-1	CFU/ 100 cm ²	Gowns /Drpaes	≤ 300	≤ 300	≤ 300	≤ 300
			Air suits	≤ 100		≤ 100	
Particle release	EN ISO 9073-10	Log ₁₀ (lint unit)	Gowns /Drpaes	≤ 4.0	≤ 4.0	≤ 4.0	≤ 4.0
			Air suits	≤ 4.0		≤ 4.0	
Liquid penetration	EN ISO 811	cm H ₂ O	Gowns	≥ 20	≥ 10	≥ 100	≥ 10
			Drapes	≥ 30			
Bursting strength - Dry	EN ISO 13938-1	kPa	Gowns /Drpaes /Air suits	≥ 40	≥ 40	≥ 40	≥ 40
Bursting strength - Wet	EN ISO 13938-1	kPa	Gowns /Drpaes	≥ 40	Not required	≥ 40	Not required
Tensile strength - Dry	EN 29073-3	N	Gowns	≥ 20	≥ 20	≥ 20	≥ 20
			Drpaes	≥ 15			
			Air suits	≥ 20		≥ 20	
Tensile strength - Wet	EN 29073-3	N	Gowns	≥ 20	Not required	≥ 20	Not required
			Drpaes	≥ 15			

ANSI/AAMI PB70:2012 Performance requirements for protective apparel and drapes

Characteristic	Test method	Unit	Requirement			
			Level 1	Level 2	Level 3	Level 4
Liquid penetration	AATCC 42	g	≤ 4.5	≤ 1.0	≤ 1.0	X
	AATCC 127	cm	X	≥ 20	≥ 50	X
	ASTM F1670	-	X	X	X	Pass
	ASTM F1671	-	X	X	X	Pass

Resistance to wet bacterial penetration, ISO 22610

This is used to determine the resistance of a material to the penetration of bacteria, carried by a liquid, when subjected to mechanical rubbing.



Resistance to dry bacterial penetration, ISO 22612

Dry bacterial penetration is a test method that was designed to simulate the penetration of bacteria-carrying skin scales through fabrics.

This test provides a means for assessing the resistance to penetration through barrier materials of bacteria-carrying particles.



Synthetic Blood / Viral Penetration for Liquid Barriers, ASTM F1670 (ISO 16603) / ASTM F1671 (ISO 16604)

The test method is used to evaluate the resistance of materials used in medical protective textiles to penetration by synthetic blood or blood-borne pathogens using Phi-X174 bacteriophage under conditions of continuous liquid contact.

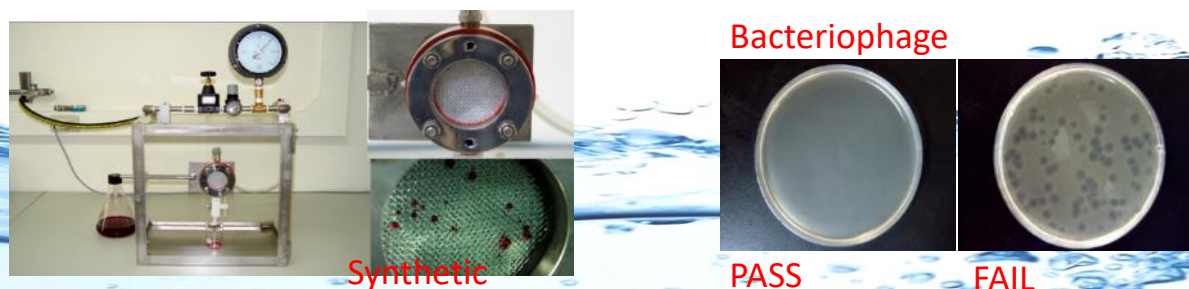

Filter Test Rig

Automatic HEPA/ULPA Filter Leak Scanning

1. EN 1822-4, ISO 29463-4 and IEST-RP-CC034
2. Dual blowers
3. Max./Min. flow rate: 3400/450 CMH
4. Oil (DEHS) or PSL aerosol generator
5. Aerosol diluter 1:100
6. Three axis motion control system
7. Operation system: PC base
8. Up to 3 particle counters for downstream
9. Particle counter: TSI 7110, 1 CFM sampling flow rate, min. detectable particle size 0.1 μ m
10. System function: automatic filter leak scanning, initial pressure drop, velocity uniformity, filtration efficiency

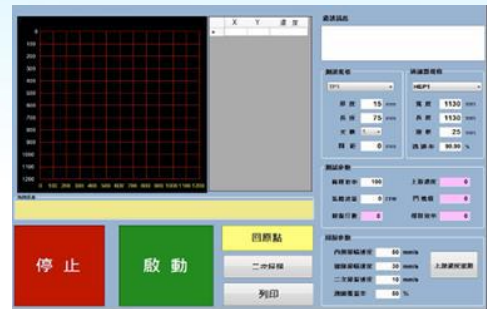
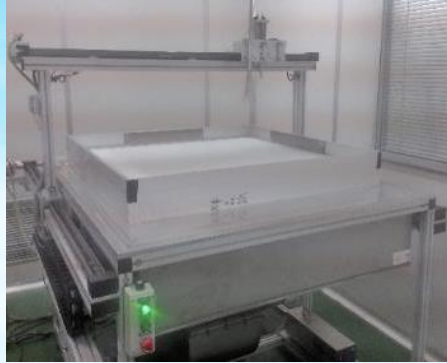

General Air Filter Test System

1. ISO 16890, EN 779 and ASHRAE 52.2
2. Max. flow rate: 5400 CMH (3000 CFM)
3. Max. filter dimension: 610 x 610 mm
4. Air cleaning with particle filters (H 13)
5. Oil / Salt aerosol generator
6. Conditioning cabinet
7. Particle counter: 1 or 2 sets, 0.1 CFM
8. Dust feeder: the feeding velocity can be adjusted acc. to the airflow rate
9. System function: resistance, fractional efficiency, arrestance and dust loading capacity.

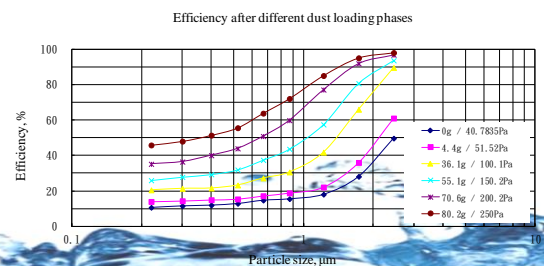

Filtration Media Test Rig

1. Max. flow rate: 110 LPM
2. Sample area: 100 cm²
3. Oil or salt aerosol generator
MMD 0.26 μ m (NaCl); 0.3 μ m (PAO or DEHS)
4. Electrostatic neutralizer
5. Two photometers
6. Up to 99.999% efficiency
7. Human machine interface
8. System function: resistance, fractional efficiency and dust loading (NaCl or PAO)



1. Max. flow rate: 1200 LPM
2. Sample area: 200 cm²
3. Oil or salt aerosol generator
4. Electrostatic neutralizer
5. Optical Particle counter:
0.3 μ m, 0.1 CFM, 1 or 2 sets
6. Dust feeder for ISO dust
7. Human machine interface
8. System function: resistance, fractional efficiency, dust loading capacity, arrestance.

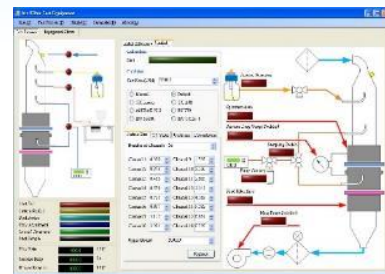
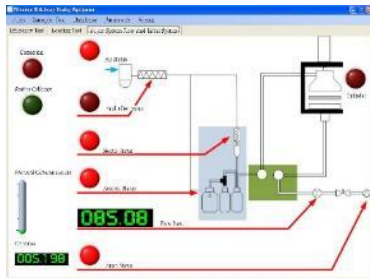

Cabin air filter testing rig

1. According to ISO 11155-1
2. Max. flow rate: 510 CMH (300 CFM)
3. Max. filter dimension: 450 x 300 mm
4. Salt (KCl) aerosol generator
5. Dust feeder for ISO dust: the feeding velocity can be adjusted acc. to the airflow rate.
6. Particle counter: 0.3 μ m, 0.1 CFM, 1 or 2 sets
7. System function: resistance, fractional efficiency, dust loading capacity, arrestance.



Engine intake air filter testing rig (Customized products)





Taiwan Textile Research Institute
No.6, Chengtian Rd., Tucheng Dist.,
New Taipei City, Taiwan

TEL: +886-2-22670321

<http://www.ttri.org.tw>

Contact name: Vincent Hu;

Fax: +886-2-22689839

<http://www.afc.org.tw>

mchu.0814@ttri.org.tw